

Parkview at University Heights

Subdivision Building and Site Design Guidelines

**Subdivision at Tyner & Ospika
Boulevards
Prince George, B.C.**

September 6 2012



**13659 - 108th Avenue, Surrey, B.C. V3T 2K4
Tel.: (604)581-5722 Fax: (604)581-4822**



INFINITY
PROPERTIES LTD

**205 – 6360 202nd Street, Langley, B.C. V2Y 1N2
Tel: (604) 532-6060 | Fax: (604) 532-1120
Email: info@infinitygrp.ca**



INDEX

TABLE OF SECTIONS

SECTION 1: INTERPRETATION AND OBJECTIVES

- 1.1 Definitions
- 1.2 Interpretation
- 1.3 Purpose of this *Schedule* of Restrictions
- 1.4 Main Design Objectives and Elements

SECTION 2: GENERAL RESTRICTIONS

- 2.1 By-law Compliance
- 2.2 Compliance Deposit
- 2.3 Design Review Fee
- 2.4 Preliminary Design Approval
- 2.5 *Final Plans and Specifications*
- 2.6 Changes to *Final Plans and Specifications*
- 2.7 Construction Completion Requirements

SECTION 3: SINGLE FAMILY LOT RESTRICTIONS

- 3.1 Drainage Easements and Rights-of-Ways
- 3.2 Siting and Setbacks
- 3.3 *Lot Grading*
- 3.4 Retaining Walls
- 3.5 Tree Preservation
- 3.6 Landscaping on the *Lot*
- 3.7 Driveways and Sidewalks
- 3.8 Fences

SECTION 4: SINGLE FAMILY DWELLING DESIGN RESTRICTIONS

- 4.1 Design Repetition
- 4.2 Single Family Dwelling Size and Permitted Home Types
- 4.3 Basement-Entry Dwellings
- 4.4 Building Height and Massing
- 4.5 Single Family Dwelling Design
- 4.6 Corner *Lot* Design



- 4.7 Roof Design
- 4.8 Roof Overhangs
- 4.9 Covered Parking
- 4.10 Balconies
- 4.11 Foundation Exposure

SECTION 5: CONSTRUCTION MATERIAL RESTRICTIONS

- 5.1 Roofing Materials
- 5.2 Fascia Boards
- 5.3 Exterior Wall Finish
- 5.4 Accent Materials and Trims
- 5.5 Windows
- 5.6 Front Entry Treatment
- 5.7 Chimneys
- 5.8 Corner *Lot* Treatment
- 5.9 Eaves and Rainwater Leaders

SECTION 6: CONSTRUCTION PROTOCOL RESTRICTIONS

- 6.1 Appearance During *Construction*
- 6.2 Condition of the *Lot*
- 6.3 Satellite Dishes, Antennas, Clotheslines
- 6.4 Use of Property
- 6.5 Signage

APPENDIX 1:

Home Sample Plans
Samples of Suitable Corner Lot Homes
Home Plan Finishing and Detailing Examples

APPENDIX 2:

Fencing Regulations

APPENDIX 3:

Supplementary Explanation and Path to Completion



SCHEDULE OF RESTRICTIONS

SECTION 1:

INTERPRETATION AND OBJECTIVES

1.1 Definitions

In this *schedule*:

"basement-entry single family dwelling – Ground Level Entry" means a single family dwelling which has two floors with the majority of sleeping areas and all living areas such as the kitchen, dining room, living room and family room all on the upper floor and the foyer and optional bedrooms and/or a bathroom on the lower floor. Unlike a *"two-storey single family dwelling"* a *"basement-entry single family dwelling"* is completely self-contained on the upper floor;

"bungalow single family dwelling – Rancher" means a single family dwelling which may have a basement as long as only one floor is visible from the highway and provided that the majority of sleeping areas and all living areas such as the kitchen, dining room, living room and family room are all on that floor visible from the highway;

"City" means the *City* of Prince George;

"construct", and any variation of that term, means to *construct*, improve, install, affix, place, or alter, or to permit *construction*, *improvement*, installation, affixation, placement or alteration;

"consultant" means Tynan Consulting Ltd.;

"developer" means the registered *owner(s)* of the fee simple or leasehold estate of all of the *lots*;

"final plans and specifications" mean the plans, specifications and other information approved by the *consultant* as per Section 2.5 of this *schedule*;

"improvements" means any building, accessory building, fence, or retaining wall *constructed* or to be *constructed* on a *lot*;



"**lot**" means each *lot* identified in either the Form 35 or the Form C to which this *schedule* is attached and any portions or portion of such *lot* which may be subdivided or consolidated whether by subdivision plan, strata plan or otherwise and "*lots*" means the aggregate of them;

"**Local Government Act**" means the Local Government Act R.S.B.C. 1996, c. 323, as amended;

"**owner**" means the registered *owner* of the fee simple or leasehold estate of a *lot*;

"**person**" means any individual, corporation, society, association, co-operative, joint venture, partnership, trust, unincorporated organization, government, or other legal entity, and includes the *owner* of a *lot* and the *developer*;

"**schedule**" means this *schedule* of restrictions and any further *schedules* or exhibits attached to it (if any);

"**split level single family dwelling**" means a single family dwelling where the upper floor does not completely cover the lower floor and in which the upper floor is limited to bedroom use only. Living areas such as the kitchen, dining room and living room are generally confined to a floor at a lower level, offset from the upper floor (this is the "split" portion). Directly below the upper floor is a floor which often contains the family room, the utility room, the mechanical room and may contain some unfinished basement area; and

"**two-storey single family dwelling**" means a single family dwelling with a minimum of two floors where bedrooms are limited to the upper floor and living areas such as the kitchen, dining room, living room and only one bedroom (if any) are exclusive to the lower floor.

1.2 Interpretation

The following provisions apply to this *schedule*:

- (a) the sections, headings, and table of contents are for convenience only, and are not for use in interpreting, defining, or limiting the scope, extent, or intent of this *schedule*;
- (b) unless otherwise specified, words importing the singular include the plural and vice versa, and words importing gender include all genders;
- (c) this *schedule* will be governed by, and is to be enforced, construed, and interpreted in accordance with the laws of British Columbia;



- (d) each provision of this *schedule* is several, and if the whole or part of any provision is invalid, illegal, or unenforceable, it will be deemed severed from this *schedule*, and this *schedule* will otherwise continue to be enforceable to the fullest extent permitted at law or at equity;
- (e) in the event of a conflict between a statute, by-law, order, regulation or agreement such as a restrictive covenant and this *schedule*, the statute, by-law, order, regulation or agreement such as a restrictive covenant supersedes this *schedule*;
- (f) for any term not defined herein, it has the same definition as in the Prince George Zoning By-law as amended from time to time;
- (g) in the event of any conflict between the *City* and the *consultant*, the *City's* position shall supersede the *consultant's* position in order to comply with the *Local Government Act*; and
- (h) the *developer* shall have the right to replace the design *consultant*, at any time, in their sole discretion.

1.3 Purpose of this *Schedule* of Restrictions

The purpose of this schedule is to ensure that all land owners within this development contribute in a meaningful and equitable manner to the development of a desirable neighbourhood.

Each *owner* should provide an attractive, well balanced, correctly proportioned, architecturally significant design to this neighbourhood. The home should be trimmed and detailed to a high modern standard, using only high quality construction materials. Yards should be graded in consideration of impact on neighbouring lots, and lots should be landscaped to a high modern standard. The final result will be that each *owner* has a highly desirable home and yard, situated in a neighbourhood in which all homes and yards are highly desirable.

Use of this schedule will ensure design continuity throughout the neighbourhood, thus maximizing the value of each *owner's* investment, and the market potential of all homes in the neighbourhood. All residents will enjoy the enhanced quality of life associated with living in a cohesive neighbourhood in which all *owners* have made a significant contribution to the overall theme.



1.4 Main Design Objectives and Elements

A person will not construct improvements except in adherence to the design objectives and main design elements to fulfill these objectives. The design objectives and main design elements are as follows:

- (a) the development is internally consistent in theme, representation, and character as determined by the *consultant*;
- (b) a high degree of compatibility is established between the proposed style theme, and the roof forms, volume allocations, and detailing features commonly associated with the intended style, as determined by the *consultant*;
- (c) each new dwelling shall be of a design that results in strong, easily recognized feature projections which are proportionally consistent with other elements on the front of the home, and which are distributed in a well balanced manner across the front façade;
- (d) the garage is to appear subdominant in relation to other elements on the front façade. The design should stress the importance of the front (human) entrance over the vehicular entrance. The front entrance and at least one other strong focal projection are to be clearly dominant to the garage;
- (e) the design of the dwelling shall be suitable for the topography of the site, and building plans shall accurately reflect actual grading conditions. Land elevations should transition smoothly from one lot to the next, and no *owner* shall construct imposing structures such as retaining walls along a common lot line with any other neighbour, unless said walls are unavoidable in which case the impact of the wall shall be minimized, as determined by the *consultant*; and
- (f) the overall quality of the *improvements*, including the *construction* components and the landscaping design and planting materials are to a high standard when compared with other new residential developments in Prince George, as determined by the *consultant*.



SECTION 2:

GENERAL RESTRICTIONS

For all of the subsections in Section 2, a *person* will not *construct improvements*, or develop the *lot* before, during or after the *construction* of the *improvements*, unless:

2.1 By-law Compliance

that *person* complies with all statutes, by-laws, orders or regulations applicable to this site, as amended from time to time. The provisions of this *schedule* do not prevent an *owner* from making an application to the Board of Variance for a variance or to the Council of the *City* for a Development Variance Permit, pursuant to the *Local Government Act*.

Regulations in this schedule do not supersede any Provincial or *City* by-laws or regulations. Where there is a conflict between this schedule and *City* by-laws, the City of Prince George by-laws shall take precedence.

2.2 Compliance Deposit

To ensure that each *person* complies with this schedule, a "Compliance Deposit" in the amount of \$7,500 is to be paid by the *owner* to the *developer* in cash or Letter of Credit prior to submission of preliminary plans to the *consultant*. In the event that all improvements are in accordance with this schedule, and are in accordance with the plans approved by the *consultant*, the compliance deposit will be returned to the *owner*. However, some or all of the compliance deposit may be withheld by the *developer* for deficiencies which may include, but are not limited to the following:

- Failure to comply with approved plans, or to obtain consent for material changes
- Failure to comply with the approved colour and materials submission
- Damages to sidewalks, curbs, driveways, utilities, neighbouring improvements
- Failure to keep the site in a clean, orderly manner
- Unauthorized dumping of materials
- Failure to remove excess excavation material from roadways, sidewalks, or neighbouring lots
- Failure to construct driveways, erect fencing, and do landscaping as required



An *owner* may apply to the *developer* for return of the compliance deposit after the *owner* obtains a passed final inspection report from either the *developer* or the *consultant*. To obtain a passed inspection report, an *owner* will have:

- Constructed the home in accordance with the approved plans
- Affixed all trim and detailing elements specified on the plans, to the structure
- Completed all exterior painting
- Completed all exterior improvements including driveways, walkways, required retaining walls, planted shrubs and trees in accordance with this schedule, and installed all fencing
- Completed cleanup of the site

In the event that an *owner* fails to complete the foregoing, or causes damages of any kind, the *developer* shall have the right to use part or all of the compliance deposit to remedy said deficiencies. In the event that remedies for deficiencies or payment for damages exceeds the amount of the compliance deposit, the *owner* shall be fully responsible for payment of additional funds to cover the cost of said deficiencies or damages. These costs shall include, but are not limited to: legal, court, architectural, engineering, survey fees, and all other costs related to enforcement of this schedule.

2.3 Design Review Fee

If not already paid by the *owner* upon the purchase of the lot, a Design Review Fee of \$495 plus HST shall be payable to the *developer*, prior to the *owner* submitting plans to the design *consultant*. This fee is not refundable. In the event that an *owner* withdraws a plan submission, and re-submits a new plan, an additional fee of \$495 plus HST will be required. After plans have been approved, an *owner* may submit a proposal to make minor changes to a plan, which will be subject to a \$100 fee plus HST.

2.4 Preliminary Design Approval

- (a) that *person* delivers to the *consultant* a submission for preliminary design approval which includes the following (digital plans are acceptable);
 - (i) site plan with home accurately located, fully dimensioned, & drawn to scale.
 - (ii) floor plans for all levels.
 - (iii) front elevation (plus flanking street elevation if *lot* is a corner *lot*)
 - (iv) detailed contact information
- (b) the *consultant* shall reply to the applicant with either a letter of acceptance, or a list of changes required for acceptance (usually via email). The *consultant* will provide the applicant with the opportunity to discuss any changes via telephone. The



developer will share all preliminary and final design approvals with the *City*.

2.5 Final Plans and Specifications

- (a) that *person* delivers to the *consultant* the *final plans and specifications*; and
- (b) that *person* does not make application to the City of Prince George for a building permit prior to receiving approval of final plans and specifications from the *consultant*.

2.6 Changes to Final Plans and Specifications

the *consultant's* written approval is required regarding any proposed changes to the *final plans and specifications*. After plans have been approved, an *owner* may submit a proposal to make minor changes to a plan, which will be subject to a \$100 fee.

2.7 Construction Completion Requirements

The *owner* or his agent must complete construction of all improvements within twelve months of the commencement of construction. Driveways may be completed within twelve (12) months. Please note that the Compliance Deposit shall be held in full by the *developer* until the driveway is built by the *owner* and/or builder.



SECTION 3:

SINGLE FAMILY LOT RESTRICTIONS

For all of the subsections in Section 3, a *person* will not *construct improvements*, or develop the *lot* before, during or after *construction* of the *improvements*, unless:

3.1 Drainage Easements and Right-of-Ways

- (a) established overland flows and/or underground storm sub-surface systems are maintained only in accordance with completed swales and *lot* grading in accordance with the *lot* grading plan approved by the *City* for the *lots*.

3.2 Siting and Setbacks

- (a) that *person* sites the *improvements* in accordance with the *lot's* natural characteristics, existing trees, and neighbouring *improvements*, as determined by the *consultant* in relation to the over-view or over-shadowing of neighbouring *lots* and *improvements*;
- (b) the siting and setbacks of the *improvements* comply with the *consultant's* requirements, which may be based on the creation of interesting streetscapes, maximization of privacy, or may be in response to conditions imposed by adjacent *improvements*;
- (c) that *person* considers all requirements of easements and rights-of-way;
- (d) that *person* has verified that the physical location of driveway and curb let-downs, significant trees, cable service boxes, electrical boxes, and streetlights does not conflict with the design or location of the *improvements*; *and*
- (e) that *person* shall be solely responsible for ensuring that the home is fully in compliance with the City of Prince George building by-laws and regulations.

3.3 Lot Grading

- (a) the design of the *improvements* is in substantial compliance with the *lot* grading plan for the *lots* which has been accepted by the *City* and approved by the *consultant*;
- (b) that *person* provides that any changes made to the *lot* do not affect the drainage pattern for the area;



- (c) the final *lot* grading at all property lines is equal to the grades indicated on the *lot* grading plan for the *lots* accepted by the *City*, and the grades on the property line between elevation points indicated on the *lot* grading plan will be equal to a linear interpolation between those points, as determined by the *consultant*; and
- (d) excavation shall not result in under-mining of neighbouring properties or the road.

3.4 Retaining Walls

- (a) there is no retaining wall, except if permitted in the *lot* grading plan accepted by the *City* for the *lots*, or as permitted by the *City*. A low profile retaining wall that is no more than 20cm [7.9 inches] in height, such as landscape ties, is not restricted, provided that such a low profile retaining wall does not result in terraced landscaping;
- (b) retaining walls, if permitted by the *City*, and if permitted by the *consultant*, have a maximum height of no more than 1.2 metres [4.0 feet], except for a retaining wall below existing grade such as concrete stairwells or covered patios under sundecks, as permitted by the *City*;
- (c) retaining walls visible from the street, if permitted by the *City*, are *constructed* of architecturally treated masonry or masonry blocks approved by the *consultant*;
- (d) a retaining wall that faces the street, if permitted, is landscaped;
- (e) retaining walls not visible from the street, if permitted, shall be *constructed* of architecturally treated masonry, or masonry blocks, or 4x4, 4x6, or 6x6 pressure treated lumber, or pressure treated landscape ties, except for a retaining wall below existing grade such as concrete stairwells or covered patios under sundecks, provided said retaining walls have been accepted in writing by the *consultant*, and are approved by the *City*; and
- (f) rock walls, if permitted by the *City*, are to be approved by the *consultant* prior to construction.

3.5 Tree Preservation

- (a) that *person* does not cut down or remove from the *lot* any existing trees beyond the proposed building envelope, driveway and other adjacent areas required to facilitate building the home, except if that *person* obtains written permission from the *consultant*, the *developer*, and the *City*.



3.6 Landscaping on Lot

- (a) that *person* plants trees on the *lot* in accordance with the final plans approved by the *consultant*;
- (b) that *person* installs the landscaping in accordance with the requirements of the latest edition of the “British Columbia Landscape Standard” published jointly by the British Columbia Society of Landscape Architects and British Columbia Nursery Trades Association, and complies with the other requirements in this section;
- (c) all street fronting yard areas on the *lot* (including flanking side yards) are to be landscaped with lawn, trees, and shrubs and flower beds according to the landscape layout submitted to the *consultant*;
- (d) in addition to the planting requirement for any trees specified in Appendix 1 herein, that *person* installs the following minimum additional planting materials:
 - (i) Shrubs: provide a minimum of 15 shrubs (3 gallon pot minimum); *and*
 - (ii) Sod: provide sod from the street to the front face of the home on an interior *lot*, or provide sod from the front and flanking streets to the front and flanking side of the home on a corner *lot*.
- (e) that *person* completes the front yard landscaping within 60 days of the completion of the *improvements*, except if weather conditions make it impossible to do so, in which case that *person* will complete that landscaping as expeditiously as possible, and prior to final inspection; *and*
- (f) that *person* cleans and grades side and rear yards within 60 days of the completion of the *improvements*, and prior to final inspection.

3.7 Driveways and Sidewalks

- (a) only the following *construction* materials for the driveway are used:
 - (i) exposed aggregate concrete,
 - (ii) pavers, *or*
 - (iii) stamped concrete, *or*
 - (iv) "broom-finish" (brushed) concrete.
- (b) the location of the driveway and sidewalks maintains open space and avoids significant trees, streetlights, or service boxes and does not conflict with drainage swales on the *lot* grading plan;



- (c) driveway locations must be approved by the *consultant*, prior to *construction*;
- (d) the maximum driveway slope measured from the centre of the driveway at the front lot line to the driveway at the centre of the garage door shall not exceed 10 percent;
- (e) the front entry sidewalk is *constructed* of the same material as the driveway; *and*
- (f) asphalt surfacing materials are not to be used anywhere on the *lot*.

3.8 Fences

- (a) Fencing design and location shall be as specified in Appendix 2 herein.



SECTION 4:

SINGLE FAMILY DWELLING DESIGN RESTRICTIONS

For all of the subsections in Section 4, a *person* will not *construct improvements*, or develop the *lot* before, during or after *construction of the improvements*, unless:

4.1 Design Repetition

the exterior design of a single family dwelling to be erected on a *lot* shall not be identical or similar to that of an existing or proposed single family dwelling on a *lot* on the same side of the fronting highway within four *lots* measured from the closest *lot* lines. A single family dwelling is deemed to have similar exterior design to an existing single family dwelling when:

- (a) the front elevation designs are identical or have insignificant variations in the disposition and articulation of design features, *or*
- (b) the front elevation designs are a mirror image to each other, with or without any variation in architectural details.

4.2 Single Family Dwelling Size and Permitted Home Types

- (a) in respect of a *two-storey single family dwelling*, the finished living area, **including** any garage and in-ground basement is not less than 148.6 square metres [1600 square feet];
- (b) in respect of a *split level single family dwelling*, the finished living area, **including** any garage and in-ground basement is not less than 148.6 square metres [1600 square feet];
- (c) in respect of a *basement-entry single family dwelling*, the finished living area, **including** any garage is not less than 148.6 square metres [1600 square feet];
- (d) **in respect of a *cathedral-entry single family dwelling*, the finished living area, including any garage is not less than 148.6 square metres [1600 square feet];**
- (e) in respect of a *bungalow single family dwelling*, the finished living area, **including** any garage and in-ground basement is not less than 130.1 square metres [1400 square feet]; *and*



- (f) other home types are not to be *constructed*.

4.3 Basement-Entry Homes / Cathedral Entry Homes

- (a) the massing design of a Basement Entry home **or of a Cathedral Entry homes** shall be indistinguishable from that of a two-storey dwelling, as determined by the *consultant*.

4.4 Building Height and Massing

- (a) the building height and massing of the *improvements* does not create a canyon effect as determined by the *consultant* in relation to the open space between the *improvements* above the first storey;
- (b) the building height and massing for *improvements* on the subject *lot* are to be compatible with the *lot* grading plan, the building height and massing of *improvements* on adjacent *lots*, as determined by the *consultant* in relation to roof design and transition in building height;
- (c) that *person* complies with those height restrictions as determined by the *consultant* in relation to views; *and*
- (d) the design of the single family dwelling incorporates the following general massing design principles, as determined by the *consultant*.
 - (i) the volume of the wall mass of individual architectural elements, such as the front entrance, the garage, and feature projections are in proportions normally associated with the declared style of the dwelling, as determined by the *consultant*; *and*
 - (ii) wall mass volumes on any street facing facade are allocated to locations on that facade in a manner that results in the achievement of overall balance in the design, as determined by the *consultant*.
- (e) **to facilitate a smooth transition in massing between a Bungalow and other homes types, strategies shall be used to increase the apparent mass of a Bungalow, as determined by the *consultant*.**



4.5 Single Family Dwelling Design

- (a) in accordance with the section on design repetition, the design of the single family dwelling is substantially as shown in Appendix 1.

4.6 Corner Lot Design

- (a) one-storey elements on the new home shall comprise a minimum of 33 percent of the width of the front and flanking street elevations of the single family dwelling;
- (b) the upper floor is set back a minimum of 0.9 metres [3'- 0"] from the one-storey elements as described in subsection (a) above;
- (c) the design achieves the objective of creating corner *lot* open sky views, as determined by the *consultant*; and
- (d) the garage faces one street and the front entrance faces the other, or the design provides for significant architectural features on both the front and flanking street sides of the dwelling, resulting in suitable architectural representation on street facing sides of the dwelling, as determined by the *consultant*.

4.7 Roof Design

(a) General

- (i) the *improvements* have a varied roof form and design as determined by the *consultant* in relation to adjacent *improvements*; and
- (ii) the roof design reduces upper floor massing as determined by the *consultant*.

(b) Pitch

- (i) the minimum roof pitch is 7:12 and the maximum roof slope is 12:12, except as provided in Clauses 4.7(b)(ii), 4.7(b)(iii) and 4.7(b)(iv) herein;
- (ii) the slope of the upper-most roof system shall be reduced where it is determined by the *consultant* that a roof slope reduction would reduce over-shadowing of neighbouring *lots*, or would preserve view corridors for neighbours, or is required due to height restrictions resulting from site conditions, as determined by the *consultant*;



- (iii) the roof pitch is constant, in accordance with Clause 4.7(b)(i), except an increased roof pitch is permitted on roofs over street facing wall projections and a decreased roof pitch is permitted at a covered entry veranda or a dormer; **and**
- (iv) **the minimum roof slope for a Bungalow type dwelling is 8:12 except as provided in Clauses 4.7(b)(ii), 4.7(b)(iii) herein.**

(c) **Roof forms**

- (i) in the *consultant's* opinion, the roof design is consistent with the intended style objectives as specified in Section 1.4, and each roof element contributes meaningfully to the overall design;
- (ii) only common hip, common gable, Dutch hip, or Boston hip roof forms are used on the main roof, as determined by the *consultant*;
- (iii) a minimum of one significant street facing common gable projection is provided on each home, as determined by the *consultant*;
- (iv) secondary projections are of a common hip, common gable, Dutch hip, Boston hip, or shed form as determined by the *consultant*; *and*
- (v) common gable roofs are not to be used above a garage.

(d) **Building Height**

- (i) the *owner* and/or builder shall be solely responsible for ensuring the home complies with height restrictions in the City of Prince George zoning by-law.

4.8 Roof Overhangs

- (a) the minimum roof overhang at the main floor level is 1'-10"
- (b) the minimum roof overhang at the upper floor level is 1'-6"; *and*
- (c) main floor roof overhangs shall exceed upper floor roof overhangs by not less than 2 inches.



4.9 Covered Parking

- (a) on all *lots*, the parking structure is limited to a two vehicle garage;
- (b) the parking structure is equipped with vehicular entrance doors that close;
- (c) the panel design on the garage doors is of a “raised panel” type that is compatible with the front entry doors, as determined by the *consultant*;
- (d) the garage is of a design which reduces the exposed wall mass over the garage door to not more than 0.7 metres [2'-4"]; *and*
- (g) triple garages may be permitted on lots of a minimum 20.0 metre width, providing the width of the garage does not exceed 55% of the width of the home, and providing the garage appears understated in relation to other elements on the front of the home, as determined by the *consultant*.

4.10 Balconies

- (a) there are no balconies, patios, decks, etc. on the front or sides of the single family dwelling, except:
 - (i) covered entry verandas are permitted at the main floor at the front side of the home and are permitted on the flanking street side of a corner lot home; *and*
 - (ii) an upper floor balcony is permitted at the front of the home, provided the balcony is integrated into and substantially concealed by a roof system extending up from the lower floor, and providing the floor area of the balcony does not exceed 5.95 square metres [64 square feet].

4.11 Foundation Exposure

- (a) exposed concrete foundations do not exceed 0.4 metres [16 inches] in height measured from the finished grade to the underside of the siding, except for stepped foundations to accommodate the finished grade of the *lot*.



SECTION 5:

CONSTRUCTION MATERIAL RESTRICTIONS

For all of the subsections in Section 5, a *person* must not *construct improvements*, or develop the *lot* before, during or after *construction* of the *improvements*, unless:

5.1 Roofing Materials

(a) General

only the following roofing materials are used:

- (i) asphalt shingles in a “shake profile” only, with a minimum 30 year warranty, which are approved by the *consultant*.

(b) Colour

- (i) only the following colours are used: grey, black, or brown.

(c) Skylights

- (i) skylights which are bubble style are not permitted on street facing elevations.
- (ii)

5.2 Fascia Boards

- (a) only the following range of colours for fascia boards and barge boards are used provided such colours are approved by the *consultant*:

- (i) colours which are complementary to the main cladding colour; *or*
- (ii) colours which are a shade variation of the main cladding colour;

- (b) fascia boards and barge boards are fully finished on all exposed sides;

- (c) where fascia boards are used, the fascia boards are of a minimum dimension of 2x8 nominal; *and*



- (d) where barge boards are used, the barge boards are of a minimum dimension of 2x10 nominal, and are accompanied by 1x4 or larger trim applied to the top side of the barge board. Composite 1 x 8 may also be acceptable at the discretion of the *consultant*.

5.3 Exterior Wall Finish

(a) General

- (i) not more than three different cladding materials, excluding trim, may be applied to any elevation.

(b) Materials

- (i) Vinyl siding may only be used on any exterior wall as approved by the *consultant*;
- (ii) only the following materials are used, with required accent materials measured as a percentage of the exposed wall face on the front facade, including window and door area:

Main cladding material	Minimum Required Accent materials
Stucco	15 percent brick or stone
Stucco	25 percent cedar, wood shingles, or hardiplank
Stucco	15 percent cedar plus 8 percent brick or stone
Cedar	None
Fibre cement board *	None
Vinyl **	20 percent cedar or wood shingles
Vinyl **	15 percent cedar plus 8 percent brick or stone

* Fibre cement board products other than Hardiplank require specific approval from the *consultant*.

** Vinyl siding must be "premium line" products offered by the manufacturer, and the profile, width, colour, and thickness shall be subject to approval of the *consultant*.



- Brick or stone veneer: Even toned in brown or grey hues only with grey or earth tone mortar.
- (ii) materials used on the other faces of the *improvements* match only the material used on the front face of the *improvements* except as follows:
 - brick or stone accent veneers are not required on all faces, but if used on the front of the structure, return at least 0.9 metres [3'-0"] around the side, except where a "pillar effect" is approved by the *consultant* the minimum return shall be equal to the width of said pillar on the front façade; where stone is used a cap made of stone or composite fascia must be used; *and*
 - wood wall accents used on the front elevation are not required on other sides of the structure, except that where wood detailing intersects an exterior corner, the wood detailing must return at least 0.9 metres [3'-0"] around the side, or meet a vertical break in the wall.

(c) Colours

- (i) only the following range of colours are used on exterior cladding materials:
 - colours from a neutral and natural (earth tone) colour palette including white, cream, greys, charcoal, browns, clay, sage, and other earth tones; *and*
 - trim or wall cladding colours outside neutral and natural colour palettes including navy blue, colonial red, and forest green;
- (ii) only the following range of colours on the trim are used:
 - lighter or darker shades of colours as specified in subsection (i) above.
- (iii) only the following range of colours on the trim are used:
 - lighter or darker shades of colours permitted for cedar siding as listed in section 5.3(c),
 - neutral colours in the cream to grey range, and other low-contrast colours which are approved by the *consultant*,
 - subdued primary colours which are approved by the *consultant*; *and*



- (iv) cedar trim is used only if it is sealed to prevent the leaching of stains onto the cladding material.

5.4 Accent Materials and Trims

- (a) accents such as brick or stone are not used unless they turn the corner and extend a minimum of 0.6 metres [2 feet] or to a vertical break in the return wall such as a chimney or a wall projection, except that where a stone or brick return is designed to simulate a column, the return shall be at least equal to the width of the column face;
- (b) brick or stone are not used as an accent on the front face unless the brick or stone covers at least 15% of the exposed wall face, preferably located at the base of the wall face, except that the regulations for accent veneers contained in section 5.3 (b) herein shall take precedence over this clause;
- (c) brick or stone on the street face is used only if the colour, pattern, and texture are compatible with the siding as determined by the *consultant*;
- (d) caps of stone or composite fascia must be used when stone is used as an accent material;
- (e) there is no use of concrete blocks or jumbo blocks which are exposed to the exterior;
- (f) only 1 x 4 nominal, 1 x 6 nominal, or larger trim is used on all street facing elevations;
- (g) there is no use of mortar unless the mortar is only grey or an earth tone approved by the *consultant*;
- (h) the base of the structure at the front of the home is defined by the use of 2x10 nominal raised base trim, or by the use of a soldier course of brick, or by the use of a stone accent material;
- (i) some of the following details should be included on all new homes: furred out wood posts, articulated wood post bases, wood dentil details, louvered wood vents, decorative wood braces, articulated gable ends, and generous trim around windows and doors which include layered or crown moldings above the entrance door and key focal openings; *and*
- (j) all trim elements specified on the *final drawings and specifications* are applied as indicated to the structure.



5.5 Windows

- (a) window openings on the front face are only of a consistent rectangular shape with the exception that a maximum of two feature windows may be of a different shape providing, in the opinion of the *consultant*, that the feature window shape contributes to both the interest and consistency of the overall theme as determined by the *consultant*; and
- (b) there are no basement windows on the front facade, except to complement unique site grading as determined by the *consultant*, or unless required by the B.C. Building code.

5.6 Front Entry Treatment and Doors

- (a) the single family dwelling does not have a front entrance exceeding a height of 3.05 metres [10'-0"] measured from the top of the stoop slab to the underside of the entry roof;
- (b) the front entrance structure shall be a more significant architectural element than the garage, as determined by the *consultant*; and
- (c) posts must land on deck or on one tread below deck.

5.7 Chimneys

- (a) all exterior chimneys visible from the street adjacent to the *lot* are *constructed* only if they are continuous to grade, with a foundation;
- (b) the single family dwelling does not include cantilevered chimney chases (including direct vent fireplaces with framed chases) if such chases are visible from the street or otherwise, except if determined otherwise by the *consultant*; and
- (c) Chimneys are to be clad in brick, stone, or in the main wall cladding material used on the dwelling.

5.8 Corner Lot Treatment

- (a) the exterior treatment of the flanking street side of the single family dwelling is the same as the front street side.



5.9 Eaves and Rainwater Leaders

- (a) the colour of gutters is complementary to or matches the colour of the fascia;
- (b) the colour of the rain water leaders is complementary to or matches the colour of the dominant wall siding material; *and*
- (c) rainwater leaders are used only if they are discreetly placed on side facing or rear facing wall planes, and do not run down the front face of the *improvements*.



SECTION 6:

CONSTRUCTION PROTOCOL RESTRICTIONS

For all of the subsections in Section 7, a *person* will not *construct improvements* or develop the *lot* before, during or after *construction* of the *improvements*, unless:

6.1 Appearance During *Construction*

- (a) at all times during the course of *construction* and the subdivision marketing process, that *person* does not permit the *lot*, and adjacent sidewalks, curbs, and streets, to be other than clean, orderly and free of debris;
- (b) within 30 days after *substantial* completion of the exterior *improvements*, that *person* does not allow any debris to remain on or about the *lot*;
- (c) there is no burning of garbage on or adjacent to the *lot* without first obtaining a burning permit from the City of Prince George; *and*
- (d) there is no washing of concrete residue into the storm sewer. The builder shall take appropriate measures to ensure that no silt-laden water enters the sewer system. Similarly, contractors shall not wash cement from exposed aggregate driveways, walkways, and walls, directly into the storm water sewer system;

6.2 Condition of the *Lot*

- (a) No *lot* shall be left in an untidy condition at any time; *and*
- (b) the *developer* reserves the right to charge an *owner* or builder for the cost of moving piles of debris and/or dirt if deemed to be unsightly and for the cost of sweeping the roads and sidewalks if the *person* does not comply with notices from either the *City* or *developer* to clean-up.

6.3 Satellite Dishes, Antennas, Clotheslines

- (a) Satellite dishes shall be discreetly placed in the yard or on locations on the home that are not directly visible from the street;
- (b) Clotheslines and antennas are not permitted.



6.4 Use of Property

- (a) No residence shall be used for any purpose other than that of a private dwelling for a single family or for the purpose of a home-based business; *and*
- (b) Residences used for the purpose of a home-based business must conform to all local and municipal by-laws including City of Prince George Bylaw No. 7850 and City of Prince George Bylaw No 7202.

6.5 Signage

- (a) Not more than one sign is permitted on any lot;
- (b) Builder marketing signs shall have a size of 4 feet in either direction;
- (c) Any and all signage is to be approved by the *developer* prior to use; *and*
- (d) Realtor signs and/or lot identification signs approved by the *developer* are exempt from the provisions in this section.



Appendix 1 - Home Plan Samples





Appendix 1 - Home Plan Samples





Appendix 1 - Samples of Suitable Corner Lot Homes

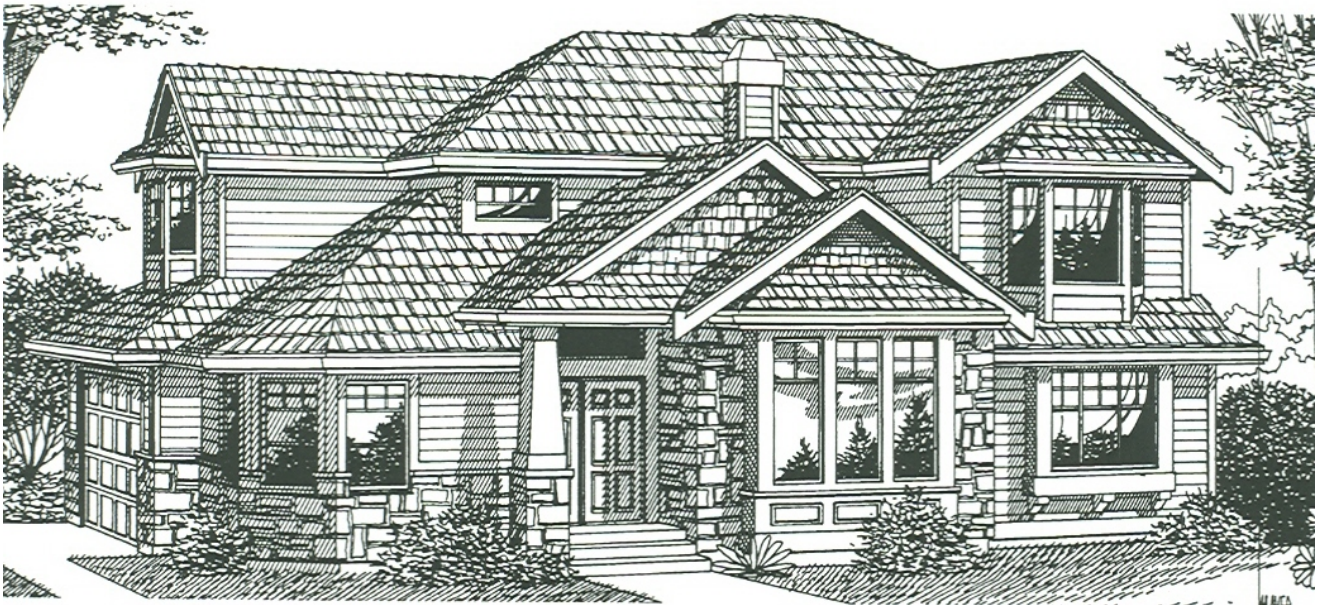
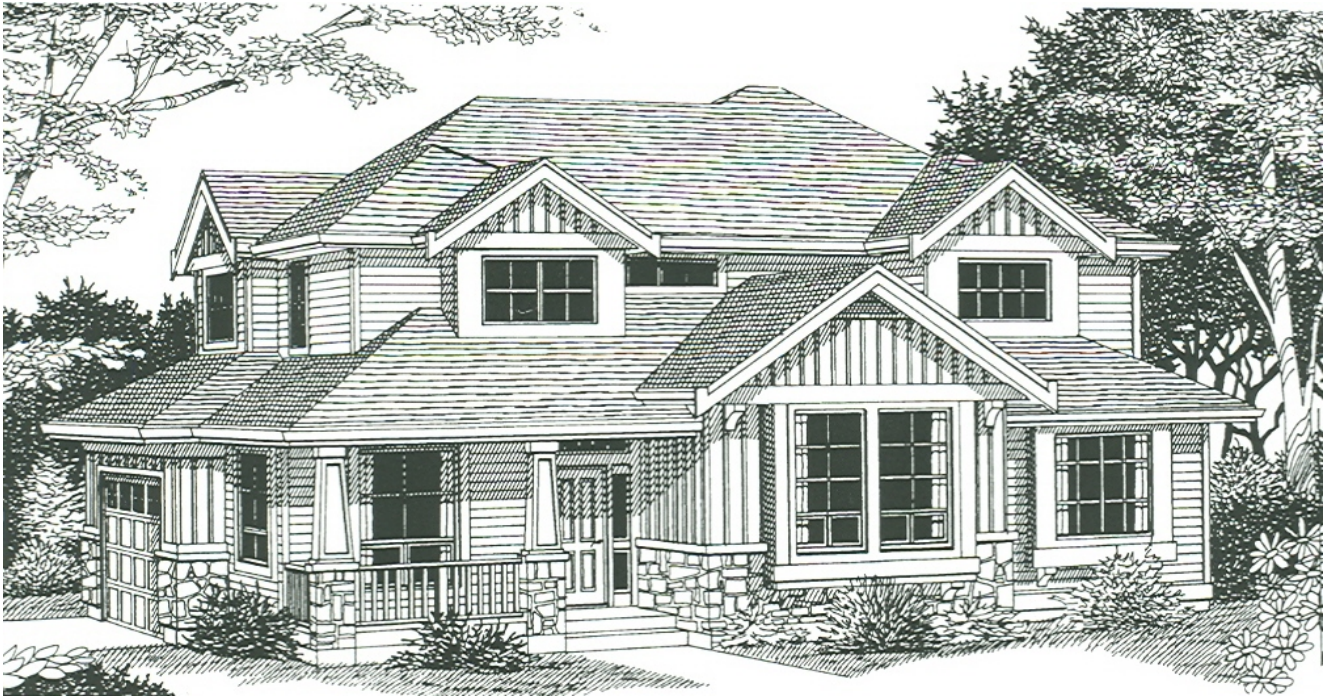



Appendix 1 - Home Plan Finishing and Detailing Examples





Appendix 2 - Fencing Regulations

Materials

1. Posts.

- Posts visible from the fronting street on an interior lot, and posts visible from the front and flanking street sides of a corner lot are to be constructed from 6x6 stock. All other fence posts should be either 4x4 or 6x6.
- Posts should be either cedar, or should be stained in a cedar colour.
- All posts should be cut no higher than 2 inches above the fence panel (measured from the highest of the panels on either side of the post).
- All posts should be capped.

All posts should be anchored with a packed gravel foundation.



2. Panels

- Fence panels are to be of one design only, as specified below. This is to avoid the awkward situation wherein one owner has a neighbour on one side with one type of fence and has a neighbour on the other side with a different type of fence, forcing an inconsistent fence appearance within the centre lot owner's rear yard.
- It is recommended that fence panels be purchased from a local supplier to ensure consistency.

Appendix 2 - Fencing Regulations



- All fences shall be 6 feet high.
- Panels should be finished with a semi-transparent stain in a natural colour.
- Panels are to step with the grade. This means that the grade has to be exactly correct before the fence panels can be installed correctly. Grades should be straight-line over as long a distance as practical, so that fence panels can step down with the grade in even increments. When installing panels, place the panel 2 inches above grade on the higher side, as illustrated in the diagram below:

Appendix 2 - Fencing Regulations

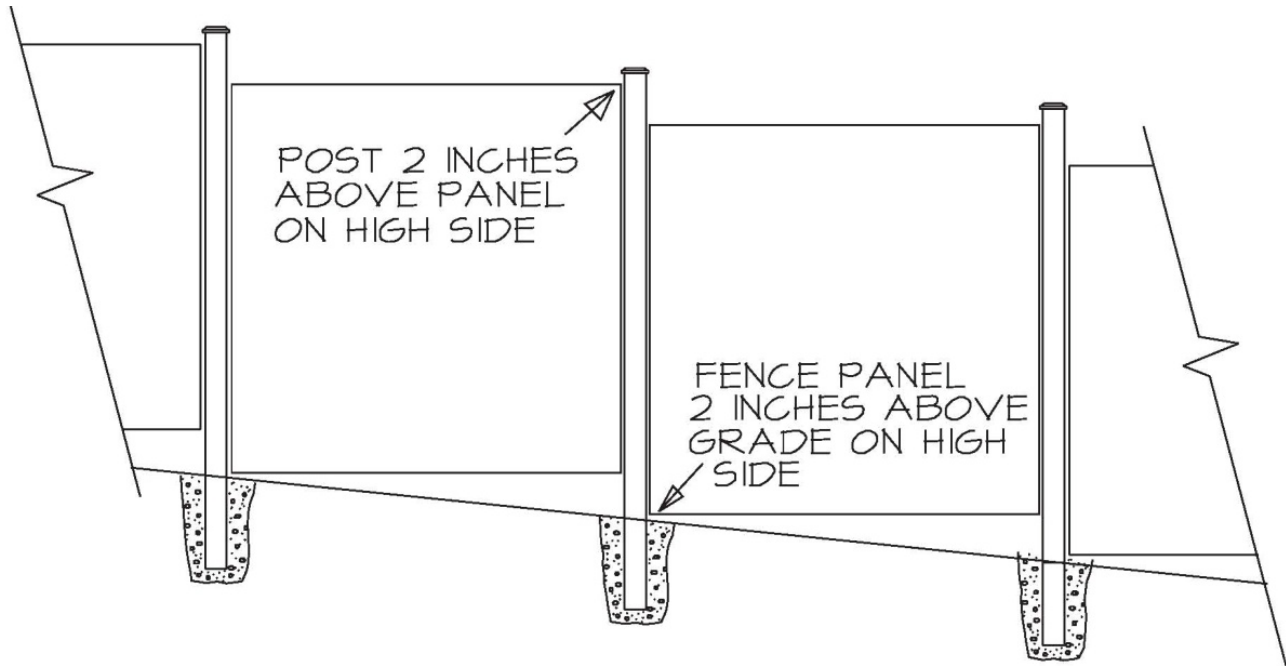

Fence Location

- 1) Fences are not permitted in front yards.
- 2) Interior lot: Fencing must be located at least 1.8m (6 feet) behind the front face of the dwelling. Reason: we do not want the fencing to appear to be an extension of the home. Fencing should be clearly subdominant to the home.
- 3) Corner lot: On the flanking street side of the home, the fence should extend from the rear lot line to a point that covers not more than half of the home. It is acceptable if it covers less. Reason: we want to expose enough of the home on the flanking street side to allow us to make an architectural statement (i.e. we don't want a fence covering the entire ground floor level). On the opposite side, the fence should be set 1.8m behind the front face of the home.



Appendix 2 - Fencing Regulations

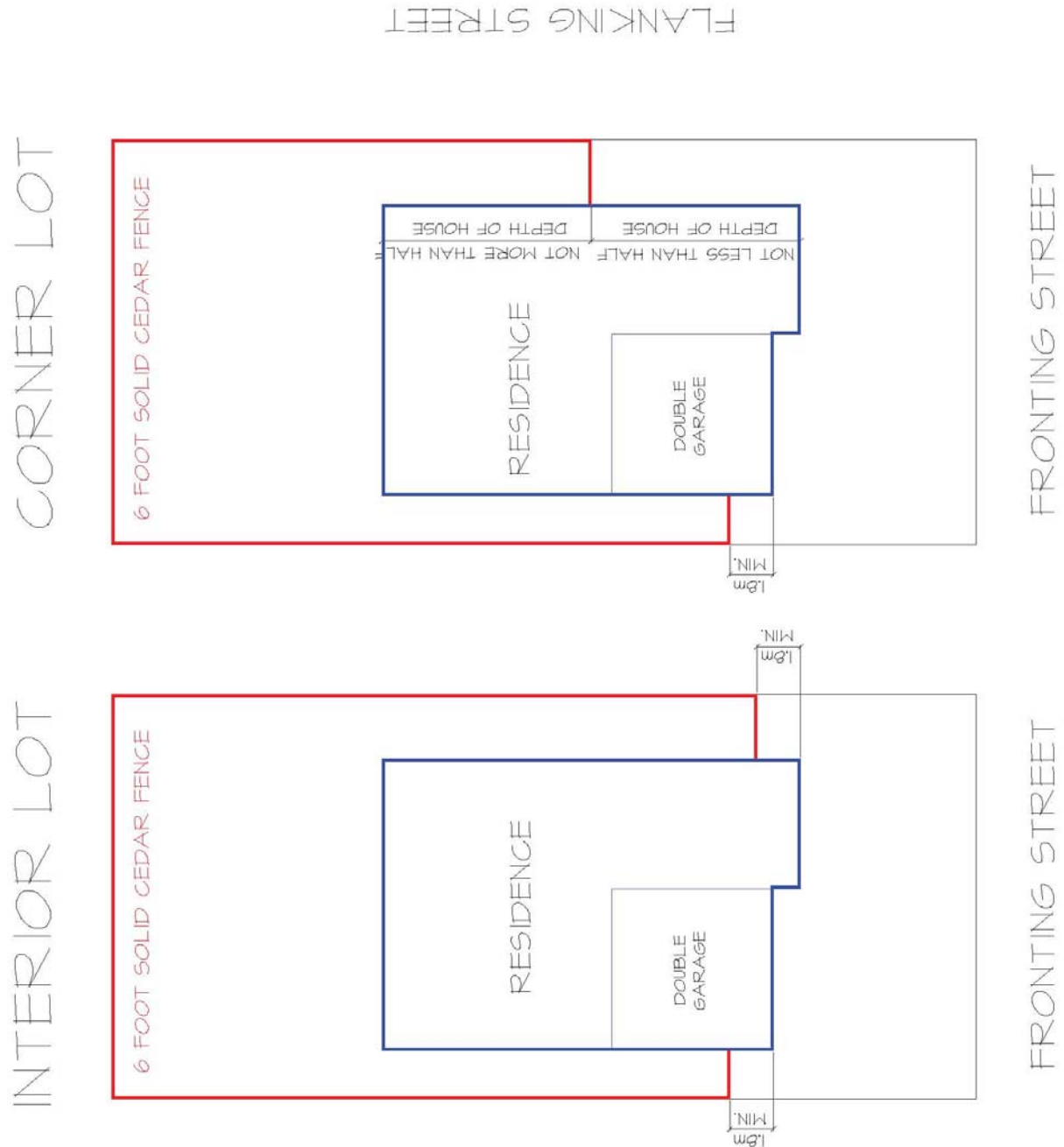



Appendix 3

Supplementary Explanation and Path to Completion

The following is intended to clarify the intent of building scheme regulations, to explain what we are planning to achieve, and to describe the entire approval process.

The intent is to create a subdivision that is readily recognizable as unique within Prince George. You should be able to drive into the area, and immediately recognize that you have arrived in the University Heights neighbourhood. This will not happen if we simply construct homes similar to what is being constructed in other neighbourhoods. There must be a unifying theme.

Currently, most new homes in this area are being constructed with a two vehicle garage that projects fully or substantially forward of the principal dwelling area. The result is that many streetscapes appear as a row of garages, with a row of houses behind. One way of creating a unique neighbourhood is to do the opposite. Instead of having a row of prominent garages along the street to serve vehicles, let's set the garage back to make the entrance for vehicles less prominent, and the entrance for humans more prominent. This is the type of fundamental change in design philosophy that can be easily recognized, especially if it is consistent. Please note that this is a recommendation and not an absolute requirement.

We can take this one step further by avoiding the use of large common gable roofs above the garage that are articulated so as to draw attention to the garage. The use of simple common hip roofs at the garage will further reduce focal attention to this element. It also follows that creating strong focal elements away from the garage will have the effect of further reducing the importance of the garage to the overall design.

The design of feature projections and elements other than the garage will determine whether the development has a "common" or "unique" identity. There should be a deliberate attempt to create one strong focal element that will form the primary identity of the home. A second focal element that is "additive" (i.e. not just a separate second focal point) can also be advantageous. However, where numerous focal points are simply spread across the front, the result will be "no clear focal point and no easily identifiable character". Focal points should be simple, elegant, and strong. We still expect good balance and expect proportionality between elements. However, if we can combine strong focal character with reduced focus on vehicles and do this consistently on many homes, not only will you be living in a desirable home, but you will be living in a desirable neighbourhood that is uniquely recognizable within this area.



Obviously, we have to be cognizant of not allowing building costs to run out of control. The design strategies specified above do not result in increased construction costs. Approximately the same amount of materials will be used on similarly sized modern homes, whether the designs are well conceived with strong simple elegant focal points oriented to humans or whether they are poorly designed assemblies of unrelated focal element with the primary focal element devoted to vehicle storage. If we achieve good design, we don't have to "over-decorate" to compensate, which can actually result in cost savings.

The shape and location of openings on the front of the home (doors and window) can have an important impact on the design. Generally speaking, the use of vertically oriented window shapes (height greater than width) will impart a subtle but recognizable estate-feel, especially if the home can be designed with upper floor windows located directly above lower floor windows. Obviously this will not be practical in all areas on the front of the home, but even some vertical alignment will have a noticeable effect. Where alignment cannot occur, some attempt should be made to balance the windows within the front façade.

An inexpensive way to "raise the bar" is to use layered barge boards (commonly thought of as fascia boards at gable ends). Using 1x4 over 1x6 over 2x10 will result in gable ends that have increased dimensionality, a trait that will not be seen on most other homes in this area. This might mean adding 50 lineal feet of 1x6 to the normal 1x4 over 2x10 standard, but will have an impact that greatly exceeds cost. Note that composite products with similar width dimensions and with thickness dimensions ranging from ¾" to 2" can be substituted.

It is better to use a small amount of brick or stone wisely, than to use a large amount unwisely. Brick and stone are meant to impart a sense of strength, foundation, and stability to a design. Brick and stone should therefore only be used where it extends down to within 8 inches of the ground level (there will be some exceptions where there are substantial side to side lot slopes). Therefore, it is not appropriate to use brick or stone on boxed out features with only air beneath. Where this is done, it makes the brick or stone appear false – like wallpaper, resulting in a negative impact rather than a positive impact. Also, brick or stone should not be used above wood posts. Stone supporting wood is one thing, but wood supporting stone is quite another. Brick or stone should be used on the upper floor only where there is brick or stone on the walls of the floor directly below. Brick and stone should not be mixed on one house.

The items above are not exhaustive, and you will likely find that I suggest minor adjustments to trim and detailing elements to ensure they are integral to the overall design.

Mike Tynan



The path to completion with the design consultant is as follows:

- 1) Ensure that the Compliance Deposit (\$7,500) has been paid to the developer.
- 2) Ensure that the Design Review Fee (\$495 plus HST) has been paid to the developer.
- 3) Make sure your designer is aware of the philosophies described above.
- 4) Owner/builder/designer sends preliminary design submission to consultant.

Send a site plan, front elevation, flanking street elevation (if corner lot), main floor plan, and upper floor plan preferably in PDF format, by email to: tynanconsulting@telus.net , or send paper copies by **fax to (604) 921-6952**.

- 5) Consultant reviews preliminary design and sends comments back.

The preliminary review will take between 1 day and 8 days based on market conditions (number of plans awaiting approval). Comments will be returned by same method as received (email or fax). If you wish to respond to this return email with comments or concerns, please feel free to do so, and I will respond back. Alternatively, you can contact **Mike Tynan by telephone at (604) 921-6912** to discuss.

- 6) Owner's designer prepares final drawings in accordance with preliminary approval.

Send final working drawings by email to tynanconsulting@telus.net. We will review these drawings to ensure that they are in conformance with approved preliminary design. After making this determination we will send you confirmation with cc to the developer. We will not stamp and sign the drawings. Rather, the owner/builder will have them printed in Prince George and then submit to the Building Department in Prince George for the purpose of acquiring a building permit. You should have a structural engineer review your drawings before submitting them for permits.

- 7) Owner/builder sends colour approval request to consultant.

Please send your colour approval requests to **Maureen King** at mking@tynandesign.net. She will normally return your colour approval within 2 or 3 days. You are welcome to discuss any comments with her. Either email Maureen at the address above, or call her at **(604) 581-5722**



8) Owner/builder constructs home and landscaping, and calls consultant for inspection.

When all improvements including all painting, exterior finishing, and landscaping are complete, please email your request to tynanconsulting@telus.net or call Mike Tynan at (604) 921-6912 to book the inspection.

9) Inspection is completed and results sent to owner and to developer.

If improvements are acceptable, the design consultant will recommend to the developer that the compliance deposit be released to the owner/builder.